

Stainless steel Swivel Davit Crane SD-SS 125-250-500

Product information



The lifting davit stainless steel 316 is a very user-friendly standing crane. Lightweight and portable. Within 3 seconds this winch is ready for use. Due to the use of 316 stainless steel, the Davit crane has a very high corrosion resistance.

- robust and safe lifting davit crane
- ready to use in 5 seconds
- integrated winch and cable in an ergonomic modern design
- easy to transport
- load pressure brake with double ratchet system for safe stable hold of the load in any position
- possible to rotate 360° due to the use of ball bearings
- adjustable crank
- including 13 meter stainless steel wire rope (d5 mm) with hook
- full stainless steel grade 316 body

Options:

- ATEX certified zone 2 and 22 (EX)

CE II 3G Ex IIC T4 Gc, -20°C<T amb <+70°C

CE II 3D Ex IIIC T135°C Dc, -20°C<T amb <+70°C

... [Read more](#)

Material: stainless steel AISI 316

Marking: According to standard

Temperature range: -20°C up to +40°C

Standard: EN 13157

Stainless steel Swivel Davit Crane SD-SS 125-250-500

Blueprint

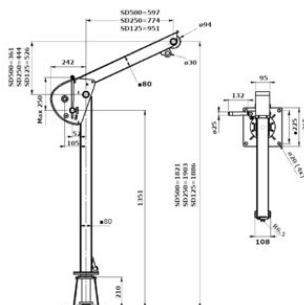

Technical data

Code	WLL ton	Rope capacity m	Capacity top layer kg	Max. Reach mm	Weight kg
SD125SS	0.125	18	125	951 mm	30
SD250SS	0.25	18	250	774 mm	30
SD500SS	0.5	18	500	597 mm	30